

## TO OUR VALUED CUSTOMERS,

This manual has been compiled to enable you to use your machine at optimum productivity.

**⚠ Before using your machine, please read carefully and store in a safe place for further reference.**

Our products have been designed to work efficiently and with the up most ease, without harming the environment.

If you experience any problems other than those discussed in our manual, please contact either the dealer from which you bought your machine or us directly and inform us about the following information:

A-Your address, telephone and fax number, machine type and production number,

B- A description of the problem.

This information is required for us to ascertain the exact problem.

We take all our customer needs seriously. Therefore, please take note that if you require a specialised unit that is not one of our standard models, we will do our up most, within reasonable parameters, to meet your needs.

We hope you enjoy using your new machine.

### ***PRODUCER:***

#### **TARIMTAŞ**

**TARIM ARAÇLARI SANAYİ VE TİCARET A.Ş.**

**IDOSB Güderi cad. No.8 F-7 Özel Parsel 34956 Tuzla/İSTANBUL**

Tel: (0216) 394 0675 - (0216) 394 0688

Fax: (0216) 394 0120

E-mail : [info@tarimtas.com](mailto:info@tarimtas.com) , [satis@tarimtas.com](mailto:satis@tarimtas.com)

Web : [www.tarimtas.com](http://www.tarimtas.com)

**Tarımtaş reserves the right to make any technical changes to its machines**, in regard to production techniques, materials used, and measurements implemented etc., based on its improvement aims and/or customer needs.

This manual has been produced for **SÜTZER** which is a trademark of **TARIMTAŞ A.Ş.** and **cannot be copied, reproduced and used for different purposes.**

## CONTENTS :

## PAGE NO

<b>1.</b>	<b>TECHNICAL INFORMATION3</b>	
<b>2.</b>	<b>TRANSPORTING AND PROTECTINGTHE MACHINE</b>	<b>4</b>
A)	TRANSPORT .....	4
B)	CHECKS AT ARRIVAL.....	4
C)	DECLARATION OF DAMAGE DURING TRANSPORT .....	4
D)	PROTECTION .....	4
<b>3.</b>	<b>OVERVIEW OF MACHINE</b>	<b>4</b>
<b>4.</b>	<b>BENEFITS OF MILKING WITH MACHINES</b>	<b>5</b>
<b>5.</b>	<b>HEALTH AND SAFETY RULES</b>	<b>5</b>
<b>6.</b>	<b>ELECTRICAL SET-UP</b>	<b>6</b>
<b>7.</b>	<b>PREPARATION AND PROCEDURE FOR MILKING</b>	<b>7</b>
<b>8.</b>	<b>POST MILKING CLEANING PROCEDURE</b>	<b>9</b>
<b>9.</b>	<b>PERIODIC MAINTENANCE</b>	<b>10</b>
	1 – Changing the Liners .....	10
	2 – Oil Check for Oil lubricated Types).....	11
	3 – Pulsator Maintenance.....	11
	4 – Cleaning the Vacuum Reservoir (Once every 3 months).....	12
	5 – Cleaning the Milk Overflow Container (Once month) (Please see p.19).....	12
	6 – Cleaning the Vacuum Adjustment Vale (every 3months) (pls see p 20) .....	12
<b>10.</b>	<b>ADJUSTING THE VACUUM PRESSURE</b>	<b>12</b>
<b>11.</b>	<b>POSSIBLE PROBLEMS AND REMEDIES</b>	<b>13</b>
<b>12.</b>	<b>SPARE PARTS</b>	<b>14</b>
	153-72-1030 - OIL RESERVOIR .....	14
	153-71-1061-A - MILKING UNIT COMPLETE FOR GOAT .....	15
	153-71-1061-B - MILKING UNIT COMPLETE FOR SHEEP .....	15
	153-71-1013 - CLUSTER COMPLETE.....	16
	153-79-1001 – SANITARY CUP (PORTABLE MACHINES) .....	17
	153-72-1019 - VACUUM ADJUSTMENT VALVE .....	18
	153-72-1004 - VACUUM PUMP (DRY OPERATED - KPM 70) .....	19
	153-72-1005 – VACUUM PUMP (OIL LUBRICATED - YPM 85) .....	21
	1530000001-2161 - SINGLE BUCKET, DOUBLE MILKING UNIT .....	23
	00–003 - SINGLE BUCKET, DOUBLE MILKING UNIT (WITH OIL LUBRICATED VACUUM PUMP ) .....	<b>Hata! Yer işareti tanımlanmamış.</b>
	00–004 - DOUBLE BUCKET, DOUBLE MILKING UNIT .....	24
<b>13.</b>	<b>CE DECLARATION</b>	<b>27</b>

## 1. TECHNICAL INFORMATION



### PORTABLE MILKING MACHINE

<b>VACUUM PUMP TYPE</b>	Dry or oil type
<b>VACUUM PUMP CAPACITY</b>	200 lt. /min. (at 50 kPa).
<b>MOTOR SPECS</b>	0.55 kW (Monophase) electric, – 1400 rpm
<b>VOLTAGE &amp; FREQUENCY</b>	220 Volt (AC) - 50 Hz.
<b>BUCKET</b>	40 Lt. / AISI 304 stainless steel – (O) Aluminium
<b>PRESSURE</b>	42 kPa
<b>OIL TYPE (in oil types)</b>	Shell Tellus 32 or equivalent.
<b>WEIGHT</b>	42 kg
<b>DIMENSIONS (w x d x h)</b>	61x110x105 cm
<b>MILKING TIME</b>	4 --7 minutes approximately
<b>MILKING CAPACITY</b>	10 - 20 cows an hour (1 - 2 cows simultaneously)

## 2. TRANSPORTING AND PROTECTING THE MACHINE

### A) TRANSPORT

During transportation, tie up the machine tight so that it does not move and get damaged.

### B) CHECKS AT ARRIVAL

At arrival, please check items below.

- Check that your machine is same as you ordered.
- Check if there is any damage due to transportation.

### C) DECLARATION OF DAMAGE DURING TRANSPORT

If there is any damage on the machine due to transportation process, an official report must be prepared together with the person responsible for transportation. This report must be signed by both you and transport responsible. Later you need to send one copy of this report to logistics company and another copy to the dealer or manufacturing company. Otherwise, we are not responsible of any damage on the machine without this report.

### D) PROTECTION

If the machine will not be used for a long time, clean the machine after milking properly with TEMZER cleaning liquids. Cover the machine properly and keep in a closed protected area.

## 3. OVERVIEW OF MACHINE

Portable milking machine is generally made of parts stated below

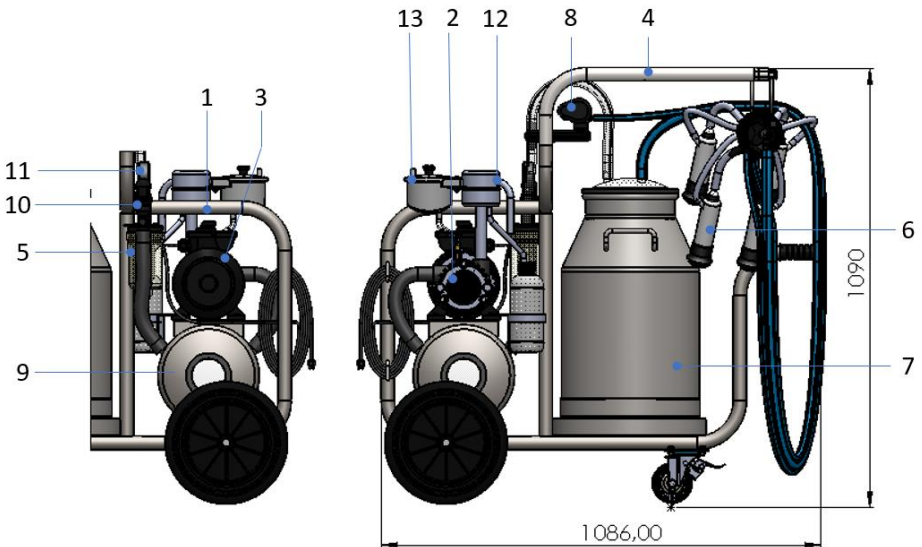

1. Frame structure	2. Vacuum pump
3. Electric motor.	4. Swing and extension arm
5. Sanitary glass	6. Milking units
7. Milk buckets	8. Pulsator.
9. Vacuum tank	10. Vacuum regulator
11. Vacuum meter.	12. Exhaust and silencer
13. Oil cup	

#### 4. BENEFITS OF MILKING WITH MACHINES

Milking is the most important process of dairy farming. Must be taken into great care and made in a healthy way. Below are the reasons why a milking machine is required even in a family-run farm with only 2 or 3 cows.

**a) Reduces milking time and increases productivity,**

As milking time approaches, cows release a hormone called OXYTOCIN. When this hormone reaches an optimum level, cows are ready to release milk.

Milking process must finish whilst this hormone is at the optimum level which generally lasts between 4 to 7 minutes. This time varies according to the breed and eating habits of each animal. Hand milking is a slower process. It is generally not possible to finish milking within this efficient hormone time by hand and therefore less milk will be obtained. Milking machine is required to finish milking within this time especially for productive culture breeds.

Machine milking reduces extraction time by nearly 50%.

**b) Protects teat health,**

Properly used good quality milking machine, reduces teat infection, and keeps illness at bay.

**c) Provides healthy and clean milk,**

Milking by machine provides cleaner and healthier milk. Milk is stored immediately in the closed protected bucket, and this prevents waste of milk, less bacteria, and increase efficiency.

**d) Provides savings on labour,**

Milking by machine will provide a healthier atmosphere where you will save time and money.

#### 5. HEALTH AND SAFETY RULES

- Do not remove the shaft protection cover at the back of the electric motor.
- Always follow the rules stated in the Electrical Set-up Section. **(Section 6)**
- Once milking is finished, remove teat cups from the animal as quick as possible **(Section 7)**.
- Always follow the stated procedures when cleaning the teat heads and the machine. Keep bucket lids closed. **(Section 8)**
- Replace the rubber teat liners every 6 months. Do not wait for them to tear. Never re-use old equipment.
- Periodically clean your machine according to the guidelines. **(Section 9)**
- Always replace cracked or ripped plastic pieces, such as the bucket lid, milk overflow container etc. Never try to fix broken parts yourself with tape or etc.
- The electric motor must never be in contact with water.
- Do not extract milk from animals with unhealthy or ill teats.
- The pulsator must never be in contact with water or oil.

**This product has been designed to be used by adults.**

**Do not allow children to get closer and operate this machine.**

## 6. ELECTRICAL SET-UP

**⚠** Electric cables must be without fault. Cable connection between barn and the machine must be installed by a qualified electrician. Electric motor must be connected to the ground line. (There is a ground wire inside the wire box.) To protect the motor from high or low voltage, a fuse or an automatic switch must be used. (Please see the examples below.) Extension cables should not be longer than 10 meters in total. This may cause low voltage and burn of motor.



Electric supply leads and cables must not be in contact with the floor. Floor is usually wet and may cause electric shock and fault of machine.

- With a portable unit, a 4-5 mm steel wire must be placed above the machine's area of operation. **(Please see the picture above)**
- Rings with diameter 6-8 cm to be placed on this wire.
- The electrical wiring required will pass through these rings and connected to the machine. This system provides ease of movement for both the machine and the electrical wiring within the machine's designated area of operation.

### EXAMPLE SYSTEMS FOR THE CONNECTION OF MAINS ELECTRICITY

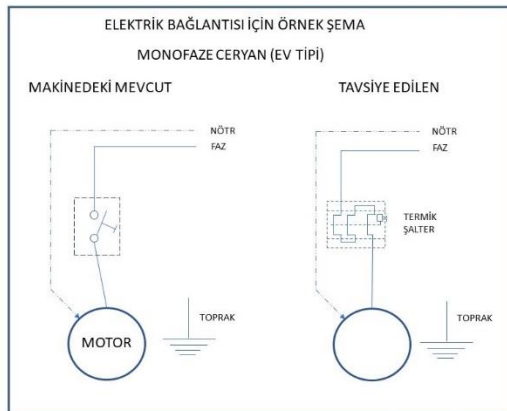

## 7. PREPARATION AND PROCEDURE FOR MILKING

### Preparing the Machine for Milking:

- Portable Units: place the unit either next to the cow requiring milking or between 2 cows
- Portable Goat Milking: place the unit either back of the goat requiring milking or back of 2 goats
- Do not move the unit too close to the animal.**
- Close the bucket lid, start the pump unit.
- On top of the cluster there is a vacuum stopper. Pull it out to close the vacuum line. (Pls see p.13). For goat and sheep machines close valves on the vacuum hoses.
- Vacuum pressure should reach 42 kPa. (40 kpa for goat milking) Check from the vacuum level indicator. **(The red line).**
- If the indicator is above or below this level (Red arrow on indicator), adjust pressure to 42 kPa for cows, 40 kpa for goats and sheep by using vacuum adjustment valve. (Pls see p.15) Once this is done you are ready to start milking.

### Preparing the Teats for Extraction:

- **Always begin milking from the back of goat/sheep or side of the cow.**
- By following the instructions on Temzer 1 mix it with warm water and prepare liquid. (Pls see p. 12) Wash the teats with this water, massage and dry them.
- First drops of milk extracted during massage are taken into the milk testing cup and visually checked. It takes approximately 1 minute for the cow teat to be ready for extraction. For goats this time is 5 to 10 seconds. The teat is ready when it starts swelling. At this point extraction must begin immediately.

### Attaching the teat cups (liners) on to the teat (Pls see p.11):

- Hold the teat head with the outside of your hand facing the floor. (Picture 1)
- Push the vacuum stopper in (for goat or sheep milking, turn the valve on hoses) and open the vacuum line. Palm of your hand holding claw glass looks up and all teat liners looking down. Attach the teat liners one by one on to each teat. To prevent loss of vacuum, hold the hoses bent (Picture 2). Start attaching the teat liners from the furthest teat for ease of application.
- If there is a sick or unusable teat, then a plastic cork is placed on to the end of the teat liner head to prevent loss of vacuum. By that plastic cork that line will be cancelled. (Picture 3)

### End of the Extraction Time:

If the milk is flowing well do not touch the teat of the animal. You can check milk flow either with the sight glass or the hose. The fastest flow is usually seen during the second or third minute after massage.

Depending on the breed of cow, extraction may take around 4 to 7 minutes.

Depending on the breed of goat, extraction takes between 1,5 to 2 minutes.

- When the flow of milk starts to slow down, pulling the teat head softly downwards and massaging the teat with a downwards movement, will enable milk to flow faster. (Picture 4).

### Removal of the Teat Head after Extraction and Checking the Teat:

After extraction is complete the teat liner must be removed quickly from the animal.

Do not leave the teat liners on the animal for long period.

- To remove teat cups, use one hand to pull out the vacuum stopper on the cluster and pull unit off the animal. Make sure that teat cups do not touch the ground. (Picture 5)

After removing the teat cups, animal's teats must be checked to see if full extraction is complete and if necessary, milking by hand must be performed. This is very important to maintain the health of each teat. When the extraction is completed successfully, no additional hand milking should be necessary. It may take some time for the animals to get used to the machine.

- Add Temzer 1 to the spray bottle (included in the unit) and spray each teat after extraction. This protects the teat from infection after each extraction procedure.
- For each animal, the procedure must be repeated starting from the beginning.



**(Pict.1)**



**(Pict. 2)**



**(Pict. 3)**



**(Pict. 4)**



**(Pict. 5)**



## 8. POST MILKING CLEANING PROCEDURE

**⚠ Alkali and acid liquid used for cleaning your equipment must be used following their guidelines and must be used after each milking cycle.**

**Do not use flammable, exploding or scouring materials when cleaning outside of your machine. Always use hot water, soap and a soft sponge.**

Once milking is complete each part in contact with milk must be cleaned. Otherwise, left-over milk will congeal, efficiency of the machine will drop, extracted milk will not be fresh and teat of the animal will become infected.

**After every milking process, follow these guidelines to clean your equipment.**

- Get two buckets of warm water. To the first bucket add Temzer 2 for morning and Temzer 3 for evening milking, following the guidelines on the stickers of cups.
- After emptying the milk from the bucket, put the clusters and milking parts into the first bucket with cleaning liquid and start the machine. All cleaning liquid will be transferred into the bucket of the machine. Then shake the bucket and pour the disinfected water back into the first bucket. This liquid can be used for cleaning the barn.
- Place the cluster into the second bucket with clean water and do the same operation as before. Once this rinsing has finished, clean the bucket of machine, empty the water out, dry the bucket and leave the bucket upside down.

Unplug machine from electric supply; store it in a closed place.

**Once a week** take off the lid of the cluster (make sure the rubber gasket doesn't fall off) and clean the inside of the cluster. Also clean the liners with the provided brush. In addition you should also clean the short and long milk hoses with the brushes provided. Make sure there are no residue milk left inside any part of the machine.

**VERY IMPORTANT:**

**Temzer 2 and Temzer 3 must be used separately. Never mix them. Mixing creates a deadly-poisonous mixture.**



Preparing the Disinfected Water



Washing and Rinsing



Equipment Cleaning Disinfectants

## 9. PERIODIC MAINTENANCE

The liners loose quality and harden within time. Small cracks occur within the rubber. This reduces quality of milk, damage teat of the animal, also milk can go inside pulsator and machine can get faulty.

**Liners should be changed every 6-8 months regardless of their condition.**

### 1 – Changing the Liners

#### How to remove

Push a blunt object to the hose end and push the milk and air hoses out. Place the sight glass against a hard place and pull the plastic out by applying pressure on to the teat head protector.

#### How to Replace

- Place the sight glass into the short hose (The milk hose)
- Place the teat cup shell over the plastic teat head.
- Take the short milk tube with the sight glass in it, lubricate it with water and push into the liners inside the teat cup. Once the short milk tube starts coming out of the other side; pull it with force, by hand.
- Place the teat assembly stick into the top of the sight glass.
- Push the stick inwards, until the sight glass and the liner go through and settle into their correct place. Remove the assembly stick. The assembly is complete. (Please see pictures below)



A



B



C



## 2 – Oil Check for Oil lubricated Types)

- Check oil levels each 50-hour working period.
- Clean the oil depot after each 500-hour working period.
- As the oil levels drop, fill with proper oil. (Shell Tellus 37 or equivalent).

## 3 – Pulsator Maintenance

The following Maintenance must be completed once a month (please see pictures below)

- Take the top lid off, remove and dispose of the old filter paper.
- Clean inside of the pulsator with a small brush.
- Fit the new filter paper.
- Place the top lid and secure the screws.



**Do not allow the pulsator to contact with oil, water or milk and do not remove any other part of the pulsator.**



**How to remove the lid of the pulsator**



**A dirty filter paper**



**How to fit the new filter paper**



**How to replace the lid of the pulsator**

**Maintenance of the Pulsator**

#### **4 – Cleaning the Vacuum Reservoir (Once every 3 months)**

- Gently pull the plug under the vacuum reservoir tank and empty any water or milk from the tank.
- Remove the plastic lids and clean the inner side of the reservoir.
- Place rubber plug and side covers back into place after cleaning.

#### **5 – Cleaning the Milk Overflow Container (Once month) (Please see p.19)**

- Twist and remove the transparent jar.
- Clean all pieces with hot water.
- If there is residue milk, gently pull the ventilator, make sure you don't remove it completely.
- After the cleaning procedure, be careful not to replace the overflow tube upside down (rubber gasket up) and if it has been moved out of place make sure to place its gasket back in.

#### **6 – Cleaning the Vacuum Adjustment Vale (every 3months) (pls see p 20)**

- Remove the lid.
- Clean the metal filter inside and place it back.

### **10. ADJUSTING THE VACUUM PRESSURE**

When the machine is working, if the vacuum indicator shows a level different than 45kPa, the vacuum pressure must be re-adjusted.

#### **• ADJUSTING THE VACUUM LEVEL**

Remove the lid of the vacuum pressure valve, loosen the two counter nuts that you can see, turn the nut at the bottom, left or right, to adjust the indicator to 42 kPa. Make sure screw does not turn together with nut. You can pull it up to prevent rotation of screw. When vacuum level adjusted hold the nut in place and tighten the nut at the top (this created a counter effect) and stabilise the vacuum pressure. Replace the lid.

## 11. POSSIBLE PROBLEMS AND REMEDIES

### 1) **The power switch is on, but the machine doesn't work.**

If there's electricity on the line but the machine doesn't work, call a qualified electrician.

### 2) **The motor is working or having trouble of working, while the pump is not working,**

- a) There could be rust on the pump or a broken vane etc. causing a blockage. Call for maintenance.
- b) A pump with a V-belt could have a loose, twisted, displaced or split belt. Dismantle the belt protection, loosen the bolts on the machine's legs, follow the instructions on the protector, stretch the belt and tighten the bolts again.

### 3) **The machine is making an abnormal sound,**

- a) The oil could have run out, in an oil type pump. Replace the oil. **(Shell Tellus 32 or equivalent)**
- b) The pump vane could be broken or worn out. Call for maintenance.

### 4) **The pump works but the vacuum pressure is low,**

- a) The bucket lid could be open. The lid gasket could be placed on incorrectly. Check the position of the lid and the gasket.
- b) The cluster, the milk overflow container or the bucket lid could have cracked. If so, replace them.
- c) The vanes could be stuck. Call for maintenance.
- d) The valve on the vacuum tank could have moved out of place or be stuck.
- e) The milk overflow siphon could have been placed upside down. If so, install it correctly. (correct : rubber gasket up)

### 5) **The machine milking is slow,**

- a) The milk cluster gasket could have fallen off during cleaning or the vacuum stopper could be blocked. (Pls see p. 18) Unblock it with the tip of a needle.
- b) There could be a tear or a hole in the milk hose. Replace it.
- c) The liners lose their elasticity over time. Replace them.
- d) The hoses linked to the machine could have a tear or be displaced. The lid of the vacuum tank or the milk overflow container might not have been placed on correctly. Replace any ripped pieces. Re-mantle any hoses that have moved out of position.
- e) If the vacuum gauge is showing a level less than 42 kPa, re-adjust it. (Pls see p. 15)
- f) If the pulsator is working sporadically (less than 60 beats per minute) or if the pulsator isn't working. Request maintenance or return to our factory.

### 6) **Water or milk is filling the overflow container (can cause a slower machine)**

- a) The hose or liners could be torn or have holes. Replace them. (Pls see p. 13)

### 7) **The vacuum pressure is normal, but it's not extracting,**

- a) The safety trap's valve house could have fallen off or become stuck.
- b) The pulsator could be faulty. Call for maintenance.
- c) The hoses which enable the vacuum to reach the teat heads could be blocked.

**12. SPARE PARTS**  
**153-72-1030 - OIL RESERVOIR**

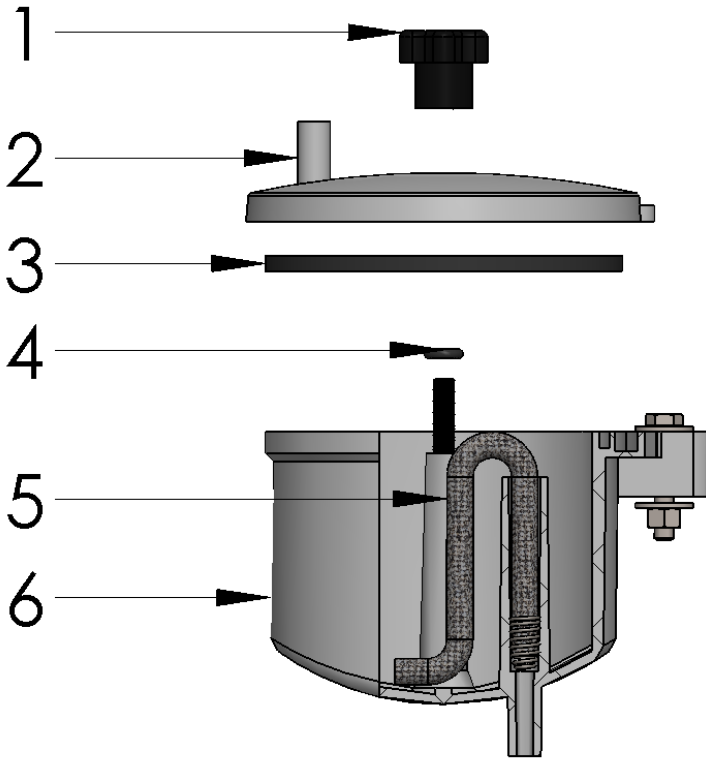

<u>List No</u>	<u>CODE No</u>	<u>PART NAME</u>
1	153-72-1047	Cover Nut
2	153-72-1081	Plastic Cover
3	153-72-1039	O-Ring (↓ 103,8x2,95)
4	153-72-1030-03	O-Ring (↓ 6,5x2,8)
5	153-72-1031-A	Oil Wick
6	153-72-1080-A	Oil Cup



**153-71-1061-A - MILKING UNIT COMPLETE FOR GOAT**  
**153-71-1061-B - MILKING UNIT COMPLETE FOR SHEEP**

<u>L. No</u>	<u>NAME OF PIECE</u>	
1	153-71-1062	Claw for sheep or goat
2	153-71-1068	Vacuum stopper valve
3	153-71-1065	Long Milk Hose
4	153-71-1066	Long Vacuum Hose
5	153-71-1079	Short milk tube
6	153-71-1080	Short Vacuum Tube
7	153-71-1067	Teat Cup
8	153-71-1063	Liner

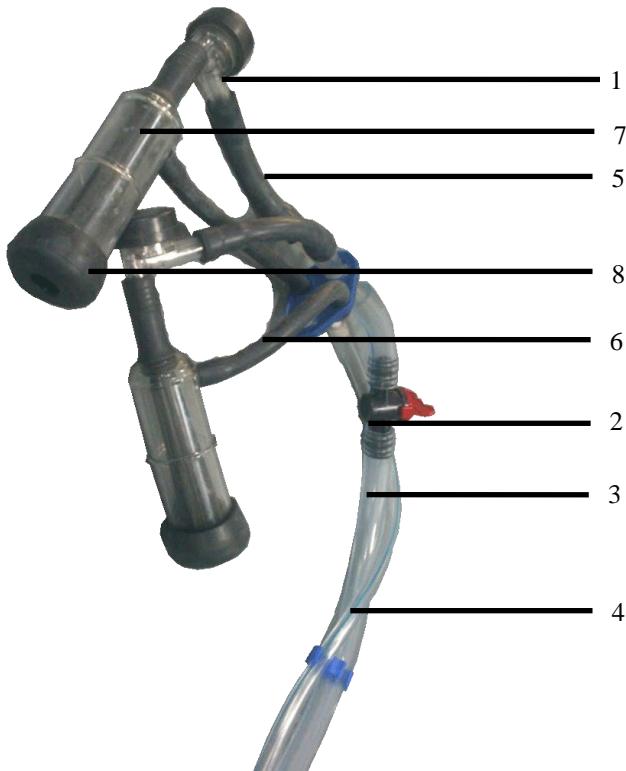

# 153-71-1013 - CLUSTER COMPLETE

NO.	PART NUMBERI	PART NAME
1	153-71-1052	CLAW COMPLETE PLASTIC 300 CC
1.1	153-71-1054-AA	CLAW BODY
1.2	153-71-1046	CLAW PROTECTION PLUG
1.3	153-71-1057	CLAW COVER SEAL
1.4	153-71-1053	CLAW COVER
1.5	153-71-1055	SHUT OFF VALVE LOCKER
1.6	153-71-1056	SHUT OFF VALVE
1.6.1	153-71-1056-01	SHUT OFF VALVE RUBBER 300 cc
1.6.2	153-71-1056-02	SHUT OFF VALVE CENTER PIM
1.7	153-71-1031	CLAW WEIGHT
1.8	153-71-1003	AIR DISTRIBUTOR
1.9	pan head tapping screw_am	
2	153-71-1006	TEAT SHELF
3	153-71-1007-AB - v2	SHORT LINER
4	153-71-1016	SIGHT GLASS
5	153-71-1010	SHORT MILK TUBE
6	153-71-1005	SHORT VACUUM HOSE
7	153-71-1005	SHORT VACUUM HOSE

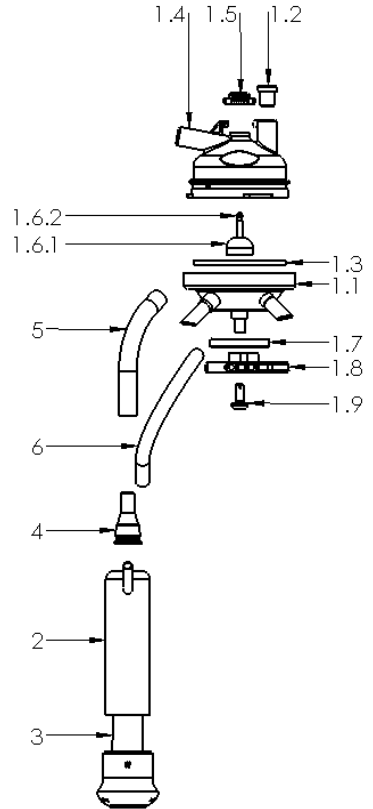



## 153-79-1001 – SANITARY CUP (PORTABLE MACHINES)

### SANITARY CUP

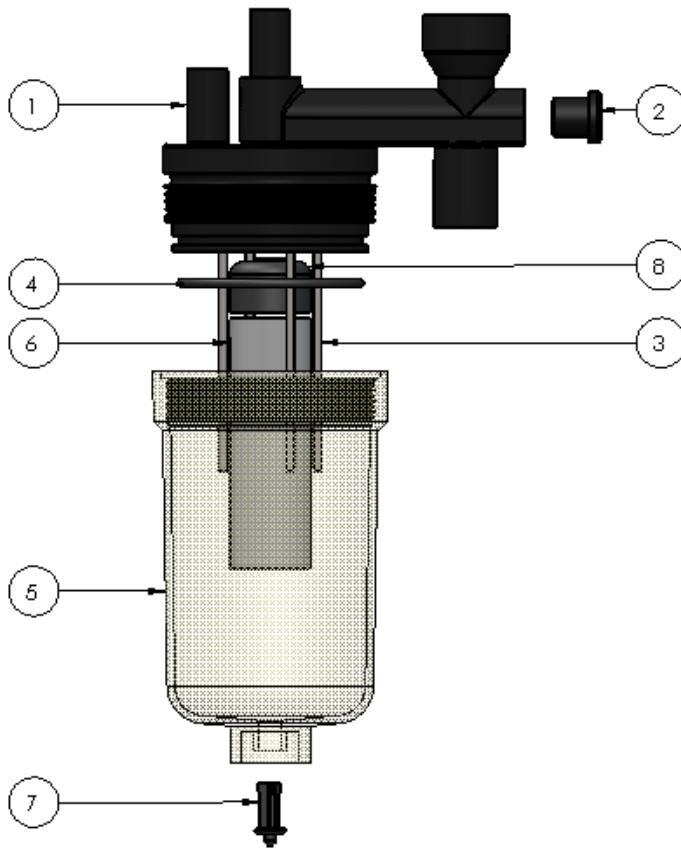

SIRA	PARÇA NO	PART NAME	ADET
1	153-79-1004_AB	SANITARY CUP COVER	1
2	153-79-1007	SANITARY CUP RUBBER PLUG	1
3	153-79-1010	SANITARY CUP HOUSING RODS	4
4	153-79-1009	SANITARY CUP O-RING	1
5	153-79-1003	SANITARY GLASS	1
6	153-79-1005	FLOAT	1
7	153-79-1002	SANITARY CUP DRAIN PLUG	1
8	153-79-1008	FLOAT COVER	1

# 153-72-1019 - VACUUM ADJUSTMENT VALVE

<u>List No</u>	<u>CODE No</u>	<u>PART NAME</u>
1	153-72-1091	Lid
2	153-72-1018	Filter
3	153-72-1092	Adjustment Spanners
4	153-72-1093	spring
5	153-72-1094	Body
6	153-72-1095	Valve

**Note:** Can be used for simultaneous milking of 1-4 cows.

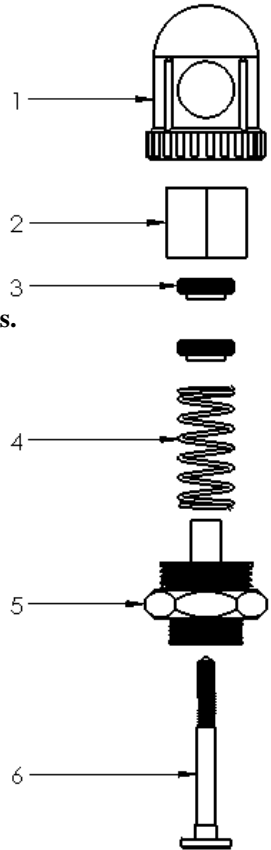

## 153-72-1004 - VACUUM PUMP (DRY OPERATED - KPM 70)

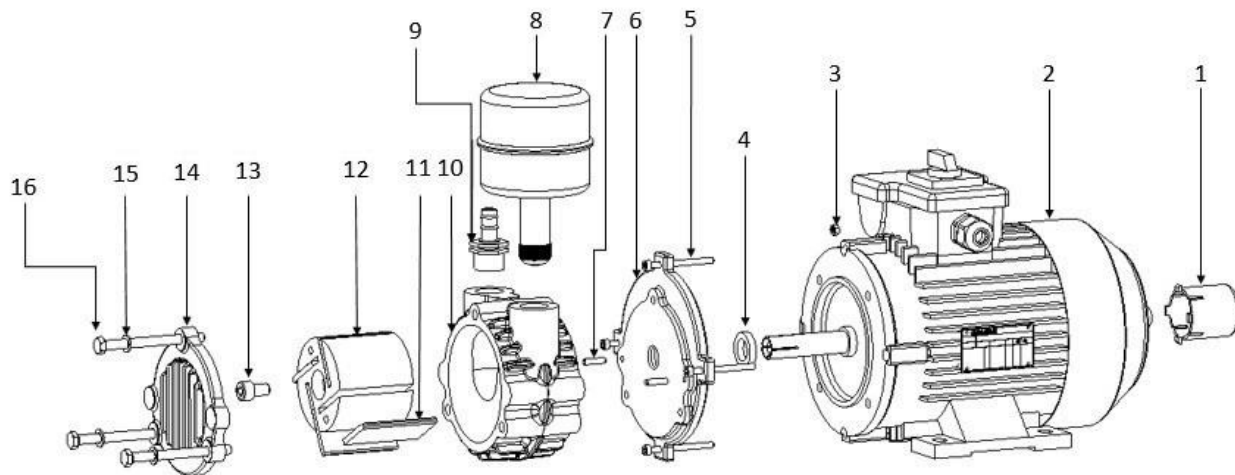

SIRA	PARÇA NO	TANIM	ADET
1	153-80-1027	MOTOR SHAFT PROTECTION	1
2	153-80-1001-B	19x73 0,55 KW MOTOR	1
3		M5 NUT	4
4	153-72-1050-A	SEAL 19x30x6	1
5		M5X60 IMBUS BOLT	4
6	153-72-1073	ADAPTER PIECE - 70-85 AKUPLE	1
7	153-72-1032-A	PIM	2
8	153-72-1042	70 DRY EXHAUST	1
9	153-72-1060-B	POMPA NIPPLE	1
10	153-72-1023-A	CYLINDER 70	1
11	153-72-1014	GRAFIT 70	4
12	153-72-1020-A	ROTOR 70	1
13		M10x16 BOLT	1
14	153-72-1107	PUMP FRONT COVER	1
15		SPRING WASHER M8	3
16		M8x95 IMBUS BOLT	3





# 153-72-1005 – VACUUM PUMP (OIL LUBRICATED - YPM 85)

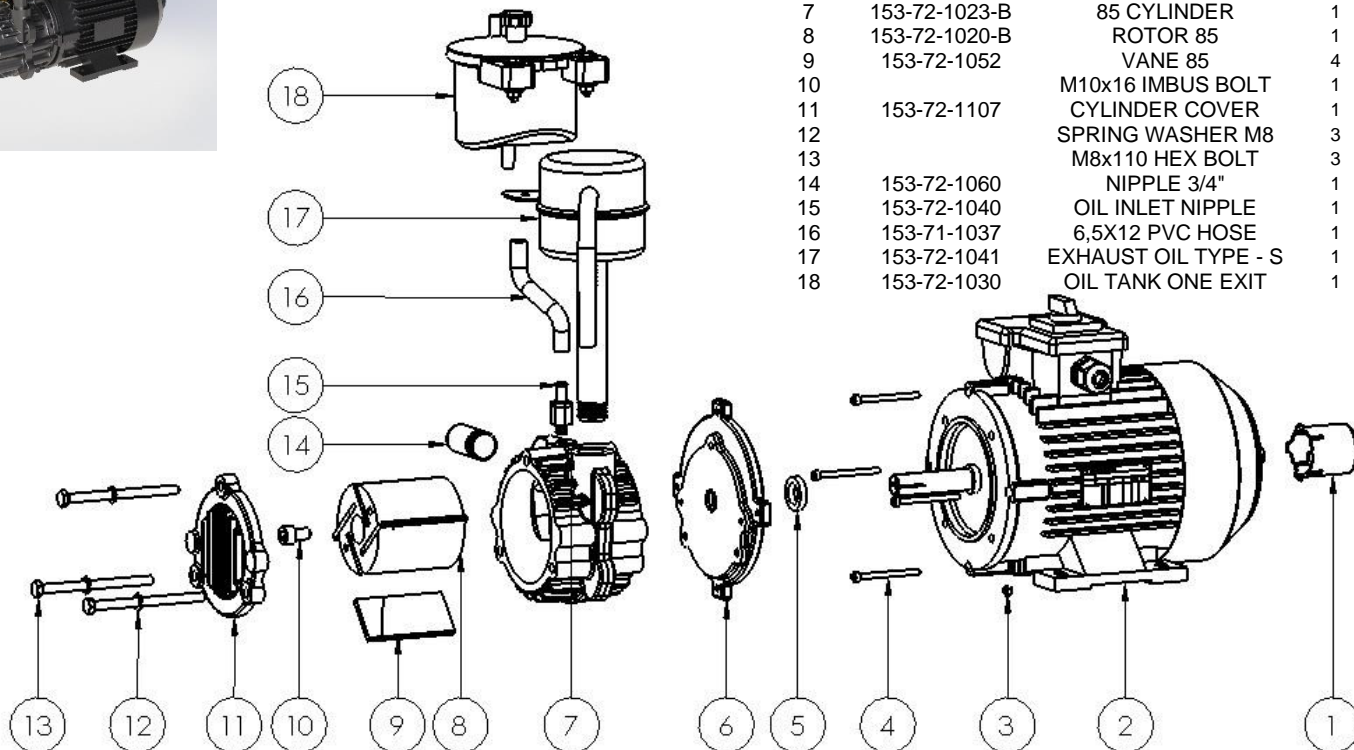

SIRA	PART NO	PART NAME	ADET
1	153-80-1027	MOTOR SHAFT COVER	1
2	153-80-1001-B	19x73 0,55 kW MOTOR	1
3		M5 HEX NUT	4
4		M5x60 IMBUS BOLT	4
5	153-72-1050-A	OIL SEAL 19x30x6	1
6	153-72-1073	ADAPTER PIECE 70-85	1
7	153-72-1023-B	85 CYLINDER	1
8	153-72-1020-B	ROTOR 85	1
9	153-72-1052	VANE 85	4
10		M10x16 IMBUS BOLT	1
11	153-72-1107	CYLINDER COVER	1
12		SPRING WASHER M8	3
13		M8x110 HEX BOLT	3
14	153-72-1060	NIPPLE 3/4"	1
15	153-72-1040	OIL INLET NIPPLE	1
16	153-71-1037	6,5X12 PVC HOSE	1
17	153-72-1041	EXHAUST OIL TYPE - S	1
18	153-72-1030	OIL TANK ONE EXIT	1

# 153000001-1101 - SINGLE BUCKET, SINGLE MILKING UNIT

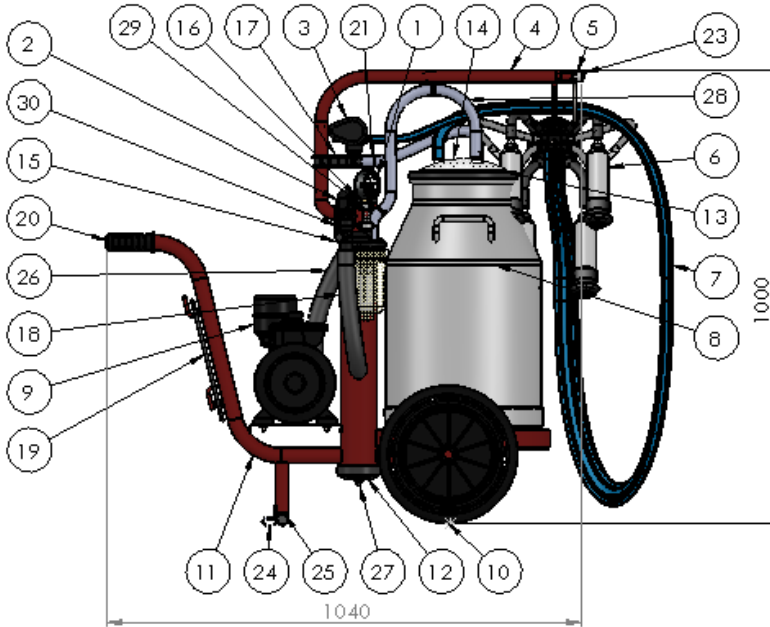

SIRA	PART NUMBER	PART NAME	ADET
1	153-75-1001	VACUUM GAUGE Ø63 SÜTZER	1
3	153-74-1002	SÜTZER PULSATOR	1
4	153-70-1014	ROTARY ARM SINGLE	1
5	153-70-1008-A	EXTENSION ARM SINGLE UNIT	1
6	153-71-1013	MILKING GROUP	1
7	153-71-1024	PVC HOSE TRIPLE BLUE	1
8	153-76-1015	BUCKET 40 LT ST ST	1
9	153-72-1004	YPM 70 DRY PUMP	1
10	153-73-1001	WHEEL	2
11	153-70-1003	SINGLE TROLLEY CHASSIS	1
12	153-70-1006	TANK BOTTOM COVER	1
13	153-76-1005	BUCKET COVER GASKET	1
14	153-76-1006	BUCKET COVER	1
16	153-70-1005	TANK TOP COVER	1
17	153-70-1009	PULSATOR ADAPTOR PIECE	1
18	153-71-1038	RUBBER HOSE	1
19	153-80-1021	POWER CABLE	1
20	153-72-1131	HANDLE	1
21	153-77-1005	VACUUM HOSE	1
22	153-70-1013-A	SINGLE ARM ROTARY PIM	1
23	153-70-1016-B	EXTENSION ARM STOPPLE	1
24	153-70-1015	GROUNDING CHAIN	2
25	153-70-1016-C	SINGLE TROLLEY FOOT COVER PL	2
26	153-71-1038	RUBBER HOSE	1
27	153-72-1045	TANK PLUG	1
28	153-77-1005	VACUUM HOSE	1
29	153-90-1039-A	CLAMP 16-23	2
30	153-95-100-01	COW BRUSH SER NO PLATE	1



# 153000001-2161 - SINGLE BUCKET, DOUBLE MILKING UNIT

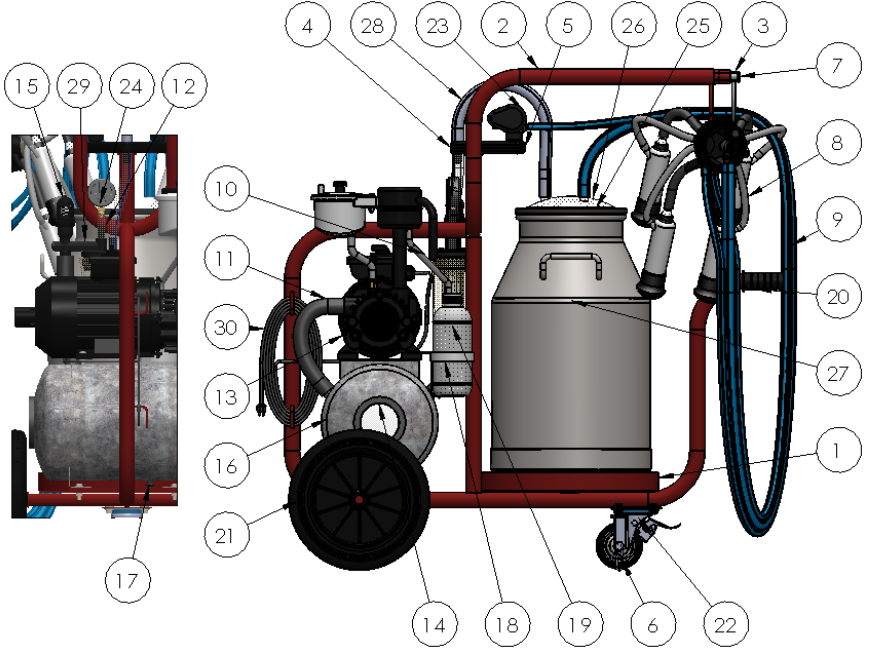

SIRA NO.	PARÇA NUMARASI	PARÇA ADI	ADET
1	153-70-1004	ÇİFTLİ ŞASE	1
2	153-70-1007	DONER KOL	2
3	153-70-1008-B	UZATMA KOLU	2
4	153-70-1011	YERLİ PULSATOR APARATI ÇİFTLİ	1
5	153-70-1012	PULSATOR APARATI TIPASI	2
6	153-70-1015	TOPRAKLAMA ZİNCİRİ	2
7	153-70-1016-A	UZATMA KOLU TIPASI	2
8	153-71-1013	SAĞIM BAŞLIĞI KOMPLE	2
9	153-71-1024	3LÜ MAVİ HORTUM KISA 1.55 M	2
10	153-71-1037	6,5x12 ŞEFFAF HORTUM	1
11	153-71-1038	KAUÇUK HORTUM	2
12	153-71-1042-01	12x21 HORTUM VAKUMMETRE BAĞLANTI	1
13	153-72-1005	YPM85 YAĞLI AKUPLE POMPA	1
14	153-72-1018-B	VAKUM TANK KAPAGI SEFFAF	2
15	153-72-1019	VAKUM AYAR SİBOPU	1
16	153-72-1034-A	VAKUM TANKI SEYYAR	1
17	153-72-1045	TANK TAPASI	1
18	153-72-1120	ATIK YAĞ KABI TUTUCU	1
19	153-72-1124	YAĞ KABI	1
20	153-72-1131	ELCİK	1
21	153-73-1001	TEKERLEK	2
22	153-73-1003	FRENLİ DÖNER TEKER	1
23	153-74-1002	SÜTZER PULSATOR	2
24	153-75-1001	VAKUM SAATI Ø63 SÜTZER	1
25	153-76-1005	GÜĞÜM KAPAK CONTASI 40LİK	1
26	153-76-1006	GÜĞÜM KAPAĞI 40 LT	2
27	153-76-1015	GÜĞÜM 40 LT PASLANMAZ	1
28	153-77-1005	PVC HORTUM	2
29	153-79-1001	SÜT TAŞMA KABI	1
30	153-80-1021	ELEKTRİK KABLOSU	1

# 1530000001-2241- DOUBLE BUCKET, DOUBLE MILKING UNIT

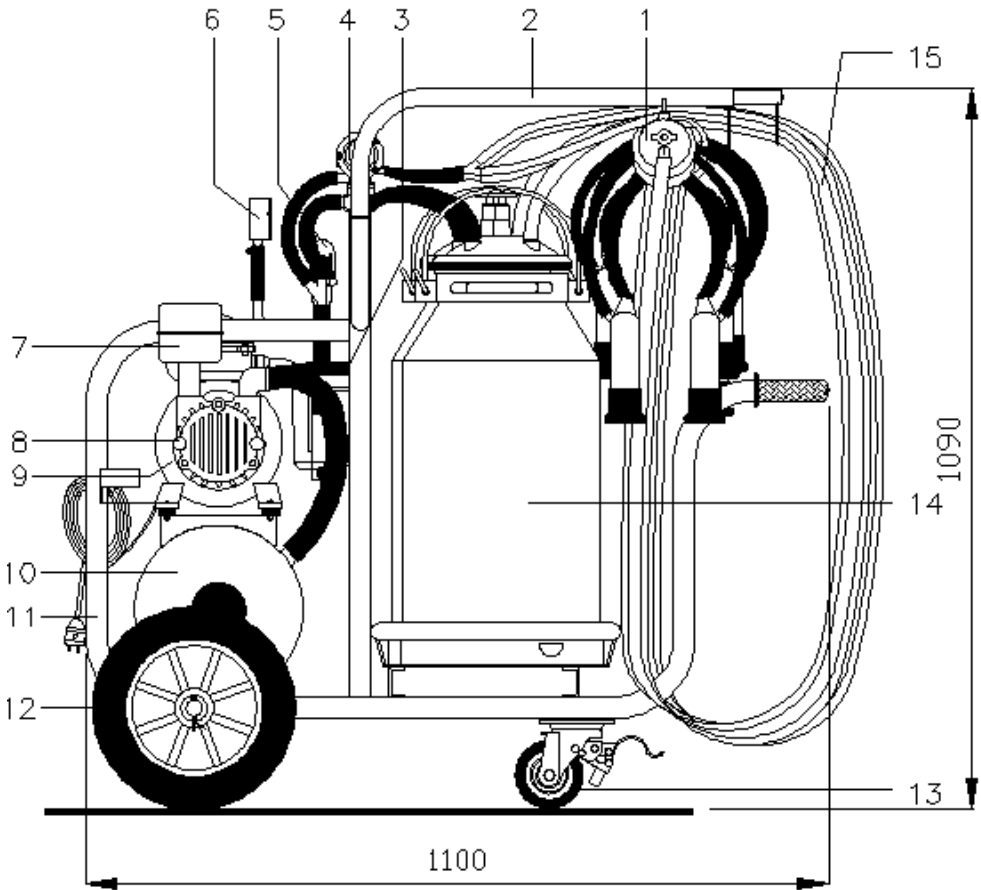

<u>List No</u>	<u>CODE No</u>	<u>NAME OF PIECE</u>
1	153-71-1023	Cluster compl. (Pls see p. 18)
2	153-70-1007	Swivel Arm and Extension
3	153-79-1001	Safety trap compl. (Pls see p. 19)
4	153-74-1002	Pulsator SÜTZER
5	153-72-1019	Vacuum Adjustment Valve
6	153-75-1001	Vacuum gauge
7	153-72-1040	Exhaust
8	153-72-1004	Vacuum Pump (KPM70) (Pls see p. 20)
9	153-80-1001	Electric Motor
10	153-72-1034	Vacuum tank
11	153-70-1004	Chassis
12	153-73-1001	Wheel (300mm)
13	153-73-1003	Sport wheel with brake
14	153-76-1014	Milk bucket (30 lt) St.St.
15	153-71-1027	Long Milk Tube Transparent
15	153-71-1028	Long Vacuum Tube Transparent





# 153000001-2461 DOUBLE BUCKET FOUR MILKING UNIT PORTABLE

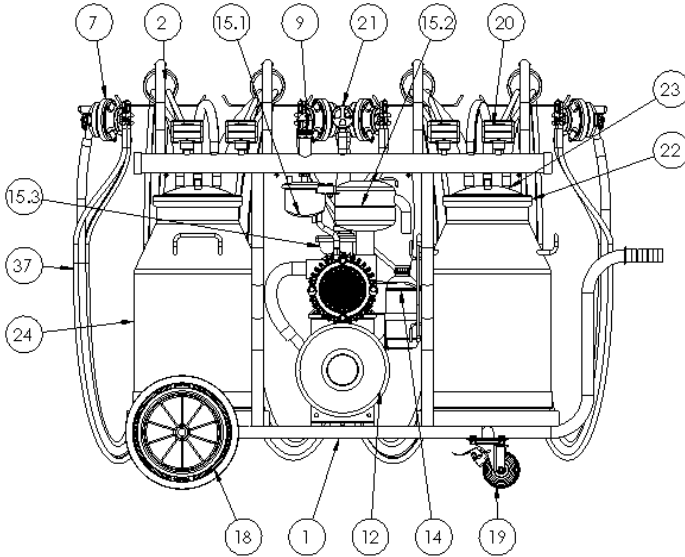

NO.	PARÇA NUMARASI	TANIM	MİKT.
1	153-70-1004_W9	ÇİFTLİ ŞASE	1
2	153-70-1014	DÖNER KOL TEKLI	4
3	153-70-1008-A	UZATMA KOLU TEKLI	4
4	153-71-1037	6,5x12 ŞEFFAF HORTUM	1
5	153-71-1038	KAUÇUK HORTUM	1
6	153-71-1042-01	12x21 HORTUM VAKUMMETRE BAĞLANTI	1
7	153-71-1052	SÜT DAĞITICI PLASTİK	4
8	153-72-1018-B	VAKUM TANK KAPAGI SEFFAF	2
9	153-72-1019	VAKUM AYAR SİBOPU	1
10	153-72-1045	TANK TAPASI	1
11	153-79-1002	SÜT TASMA KABI ALT TAPASI	4
12	153-72-1034-A	VAKUM TANKI SEYYAR	1
13	153-72-1120	ATIK YAĞ KABI TUTUCU	1
14	153-72-1124	YAĞ KABI	1
15	153-72-1128-BA	VAKUM POMPASI	1
15,1	153-72-1030	YAGDANLIK TEK ÇIKIŞLI	1
15,2	153-72-1043-B	YPM 90 EGZOST	1
15,3	153-80-1004-A	1,5 kW MOTOR	1
16	153-72-1131	ELCİK	1
17	153-72-1161	KAUÇUK TAPA 1 1/2"	2
18	153-73-1001	TEKERLEK	2
19	153-73-1003	FRENLİ DÖNER TEKER	2
20	153-74-1002	SÜTZER PULSATÖR	4
21	153-75-1001	VAKUM SAATI Ø63 SÜTZER	1
22	153-76-1005	GÜÇÜM KAPAK CONTASI 40LİK	2
23	153-76-1006	GÜÇÜM KAPAGI 40 LT	2
24	153-76-1015	GÜÇÜM 40 LT PASLANMAZ	2
25	153-77-1005	PVC HORTUM	2
26	153-80-1027	MOTOR MİL MUHAFAZASI	1
27	153-80-1021	ELEKTRİK KABLOSU	1
28	153-90-1039-A	HORTUM KELEPÇESİ 16-23	2
29	Preferred Wide FW 0.3125		32
30	DIN EN 24017 - M8 x 30-N		8
31	Hexagon Nut ISO 4034 - M8 - N		16
32	DIN 94-5x36-C-St		2
33	153-71-1038	KAUÇUK HORTUM	1
34	153-77-1005	PVC HORTUM	1
35	153-77-1005	PVC HORTUM	1
36	153-77-1005	PVC HORTUM	1
37	153-77-1005	PVC HORTUM	1
38	DIN EN 24017 - M8 x 16-N		8

### 13. WARRANTY CONDITIONS

Machine is guaranteed for **2 (two) years** to the customer from the date of invoice against material, workmanship and production faults. Electric motor is out of warranty.

2) No labor, parts or similar fees will be charged for transactions within the scope of the warranty.

3) Our company completely determines the technical method applied and the part to be replaced when troubleshooting.

4) Customer approval is required to perform the repair.

4) If it is not possible to repair the fault according to the determination of our technical service, the product will be replaced free of charge.

5) If the consumer does not comply with the following,

- Using the product other than as shown in the user manual
- Maintenance and repair by persons other than authorized technical service,
- Damages during loading and transportation
- Too low or too high voltage, faulty electrical installation,
- Malfunctions as a result of events such as fire, lightning and etc.
- If by the seller company, the warranty card is given to the customer as incomplete, unsigned or without stamp, or else if it is not given at all, the product is out of warranty.

**Maintenance and repair will be made for a fee for malfunctions which are not covered by the warranty.**

## 14. CE DECLARATION



QA-AC-2281/16

QA TECHNIC – UYGUNLUK ONAYI  
QA TECHNIC – ATTESTATION OF CONFORMITY

MAKİNA EMNİYETİ YÖNETMELİĞİ (2006/42/AT)  
MACHINERY DIRECTIVE (2006/42/EC)

TARIMTAŞ TARIM ARAÇLARI SAN. VE TİC. A.Ş.  
TUZLA ÖRG. DERİ SAN. BÖLG. GÜDERİ CD.NO:8 F-7 PARSEL TUZLA  
İSTANBUL /TURKEY

Ürünün Tanımı Description of the Product/Product Part	: SÜT SAĞMA MAKİNASI VE SÜT SAĞIM TESİSLERİ MILKING MACHINES AND MILK RELAXING PLANT
Markası Product Commercial Brand	:  <b>TARIMTAŞ</b>
Ürün Tipi Product Type	: TEK GÜŞÜM TEK SAĞIM, TEK GÜŞÜM İKİ SAĞIM, İKİ GÜŞÜM İKİ SAĞIM SÜT SAĞMA MAKİNELERİ, YARI SABİT SÜT SAĞIM TESİSLERİ VE MUHTELİF KAPASİTEDE YIKILIM POMPA GRUPLARI
Uygulanabilir AT Direktifi Applicable EC Directives	: 2006/42/AT 2006/42/EC
Uygulanabilir Harmonize Standartlar Uygulanabilir Ulusal Standartlar Ve Teknik Spesifikasyonlar Applicable Harmonized Standards/ Applicable National Technical Standards	: TS EN ISO 12100:2010, TS EN 60204-1
Rapor No & Rapor Tarihi Report No & Report Date	: M-LVD-1394/18, 02.05.2018

İşbu belge incelenmesi yapılan ürün tasarımı için geçerlidir. Ürünün değiştirilmesi halinde bu belge geçerliliğini kaybedecektir.  
Ürünün ilgili direktif / direktiflere uygunluğa ile ilgili sorumluluk üretici firmaya aittir.  
The present certificate is valid just for the analysed product design. The certificate shall lose its validity in case of any changes  
in the product. Ultimate responsibility related with conformity of product with directive / directives, belongs to manufacturer.

İlgili yönetmelikler ve yasal mevzuat gereği (örneğin  
Ultimate responsibility regarding the affixing of  
bearing manufacturer.



İşareti belirlemesi ile ilgili sorumluluk üreticiye aittir.  
mark according to relevant regulations and legal legislation.

Sertifika Yayın Tarihi : 17.04.2018  
Certificate Issue Date  
Geçerlilik Tarihi : 25.04.2024  
Validity Date

ALBİREK ÇELİK İNŞAAT VE TARIM  
MÜHÜRÜ, 90 BELGELENDİRME A.Ş.  
BARBAROS MAH. AK ZARIFAR SOY.  
A BLOK KAT:19 NO:2 A/ŞİŞLİ  
İSTANBUL / TÜRKİYE  
Tel : 0090 312 81 10 11-12  
Fax : 0090 312 81 41 14  
www.gpttrk.com.tr



L. Murat YILMAZ  
Yönetim Kurulu Başkanı  
Chairman Of Executive Board